

## MICROCONTROLLER BASED SOLAR POWERED AUTOMATIC STREET LIGHT INTENSITY CONTROLLER

URJA JAIN<sup>1</sup>, ANINDYA JAIN<sup>2</sup>, DEEPALI SHUKLA<sup>3</sup>

<sup>1</sup>Department of Electronics and Communication, Medi-Caps Institute of Science and Technology, Indore, Madhya Pradesh, India.

<sup>2</sup>Department of Electronics and Communication, Jaypee Institute of Information and Technology, Noida, Uttar Pradesh, India.  
Email: urja27@gmail.com

Received: 23 March 2018, Revised and Accepted: 29 May 2018

### ABSTRACT

**Objective:** The main purpose of this paper is to design and execute the system to control the intensity of the street light without any manual operation.

**Methods:** The system is based on the principle of light and motion sensing. The system is made efficient enough by replacing the HID lamps with the LEDs. In general, street lights on the highways are designed with high-intensity lamps that consume more energy and also cannot be changed as per the requirement. Thus, the proposed system overcomes these problems using LEDs instead of HID lamps in the street light systems. It is the Dual Power Saver setup since it saves power with the help of solar energy which charges the battery of the circuit using the solar panel and second by just increasing the intensity of the LED in the presence of a pedestrian or a vehicle using the suitable combination of microcontroller and IR sensors. The Microcontroller AT89c51 is used for control mechanism of the system.

**Results and Conclusion:** The smart street light control system adopts a dynamic control methodology. According to the proposed plan, initially, when it becomes dark, all the street lights automatically glows with low intensity. However, throughout the night streetlights remain switched on for security concerns on low intensity. When a vehicle passes by, a block of street lights glows, and as the vehicle moves forward, the next block of lights starts glowing where the previous block switches back to low intensity. Whereas, lights will be kept OFF when there is sufficient amount of natural light is available. The proposed work would help in reducing the overall consumption of street light energy and support to energy-saving aspects of the nations.

**Keywords:** Microcontroller, Street lights, Dynamic control methodology, Energy saving

### INTRODUCTION

In early days, streetlights on the roads were manually controlled. However, because of the enhancement in the technology and by the introduction of automated systems, nowadays street lights are controlled automatically that does not require any manual effort. Electricity is the major demand in the developing countries like India. One of the major areas where power is consumed is in street lighting. It is found that there is wastage of power by operating the street lights due to manual operation [1]; thus, it needs to be conserved. As there is no necessity of light with high intensity in peak hours that is when there is no traffic or when there is sufficient amount of natural light is present. Thus, by reducing the intensity of light using LEDs, the energy can be conserved.

The idea of designing a new system for the streetlight that does not consume a huge amount of electricity and illuminates large areas with the highest intensity of light is concerning each engineer working in this field. Providing street lighting is one of the most important and expensive responsibilities of a city. Lighting can account for 10–38% of the total energy bill in typical cities worldwide [2].

Manual control is prone to errors and leads to energy wastages and manually dimming during midnight is impracticable. Furthermore, dynamically tracking the light level is manually impracticable since in the field of electronics automated systems gives good performance and reliability. Therefore, the current trend is the introduction of automation and remote management solutions to control street lighting [3].

In the present scenario, automated systems have a less manual operation, high flexibility, and accuracy. The main purpose of the system is to control the switching of street lights automatically.

The system is designed for LED-based street lights with auto intensity control using solar power from photovoltaic cells. As awareness of solar energy is increasing, more and more individuals and institutions are opting for solar energy. Photovoltaic panels are used for charging batteries by converting the sunlight into electricity. A charge controller circuit is used to control the charging.

Intensity of street lights is required to be kept high during the peak hours. As the traffic on the roads tends to decrease slowly in late nights, the intensity can be reduced progressively till morning to save energy. Thus, the street lights switch ON at dusk and then switch OFF at dawn automatically. The process repeats every day.

As the street lights are always ON even when there is no vehicle or no person nearby, so there are enormous electricity and energy loss. Hence, energy conservation was our aim for this project keeping in mind the Project of Smart city proposed by many countries. We laid down our efforts for the project of the automatic working of street lights.

### METHODOLOGY

The block diagram of the system is shown in Fig. 1.

- i. The solar panel used in this project is a photovoltaic cell of 6 V and 3 W, which is used to charge the battery by utilizing the energy of the sunlight.
- ii. Battery used in this system is rechargeable with a voltage rating of 6 V.
- iii. LM324: It is 14 Pin IC, consist of four amplifiers per package. It operates on supply voltage ranging from 3 V to 32 V. It is made using four internally compensated, and two-stage OPAMP, consisting of short-circuiting protected outputs. It has low input bias currents.
- iv. Microcontroller (AT89c51): It is a 40 pin IC, consisting of 32 input-output programmable lines and two 16-bit timer/counter. It has 6 interrupts, and also it has 128 × 8-bit Internal RAM. It is low power,

- v. high-performance IC, having temperature stability >0.005%.
- vi. ULN 2803 IC: It is high voltage, high current transistor array IC used especially with Microcontrollers where we need to drive high power loads. It consists of an eight NPN Darlington connected transistors which provide the proper current amplification required by the loads and are used to drive high loads such as lamps, relays, and motors.
- vii. Relays: These are the simple switches, which are operated both electrically and mechanically where only a low power signal can be used to control a circuit and is also operated where only one signal can be used to control a lot of circuits. It is used to switch the signal coming from one source to another destination. There are only four main parts in a relay: (1) Electromagnet, (2) movable armature, (3) switch point contacts, and (4) spring.
- viii. IR Sensors [4]: An infrared sensor is an electronic device used to sense certain characteristics in its surroundings by emitting IR radiations. They are capable of measuring the heat of an object as well as detect the motion of the object.
- ix. Light-dependent resistances (LDR) [5]: It is used as a light detector, and its resistance varies according to the amount of light falling on its surface. When LDR detects light, its resistance will decrease, thus if it detects darkness its resistance will increase. It has high switching time, high reliability, and lightweight.
- x. LM555 Timer: It is 8 pin IC, a highly stable device for generating accurate time delay. It operates in both as table and monostable states. It gives normally ON or normally OFF output. It is used to turn ON LED for specific time duration in the monostable state.

**Implementation**

Negative terminal of the battery was connected to the negative terminal of the solar panel and the positive terminal to relay. Further, relay was connected to pin 3 of 555 Timer through Transducer. For the first part there was the use of LDR which is capable to sense even the little darkness of the surroundings. LDR was connected to pin 2 (trigger pin) of the 555 timer, which was responsible for driving the IC. Here, 555 Timer is used which helps to analyze the interrupt from LDR which in term helps us to switch between three modes of relay. It adjusts the intensity of LEDs in a given period of time. LDR sends interrupt on IC and through pin 3, relay controls the battery whether to store the energy from sunlight or to glow in dark. The second is LM324 which was used to support the IR sensors and LEDs through relays, which are derived with the help of ULN2803, as the microcontroller cannot drive three relays at a time. LM324 consists of 4 op amps, which acts as a comparator. IR sensors have a transmitter which was connected to pin 3 of LM324. The receiver of IR sensor was on pin 2 of LM324 and same was repeated for other opamps in that IC. Pin 1, 7, 8, and 14 which are the output of LM324, acts as a input for microcontroller. Microcontroller AT89C51 is being used. Outputs of LM324 were given on pin 1, 3, 5, and 7 as input to 89C51. Pin 1-8 were acting as Port 1 for 4 i/p. Pin 9 was reset pin. Pin 10-17 were acting as Port 3. Pin 18 and 19 were connected with crystal oscillator. Pin 20 was ground. Pin 21-28 were taken as Port 2 which acts as an o/p for the given i/p. Pin 32-39 were taken as Port 0 and pin 40 was Vcc. o/p. From pin 21, 23, and 25 of 89C51 acts as an i/p form ULN2803. ULN2803 was introduced to derive the relays which were further connected to LED(s). Pins 1, 3, and 5 are the i/p pins and pins 16, 14, and 12 are the o/p pins of ULN2803, which drive the relays. When these relays are energized, the intensity of LED(s) are controlled. It is used to control 3-4 LED bulbs. An operational amplifier with comparator and Zener diode cutoff circuit is used to prevent the battery from overcharging (Figs. 2-6).

**RESULTS AND DISCUSSION**

1. The smart street light control system adopts a dynamic control methodology. According to the proposed plan, initially, when it becomes dark, all the street lights automatically glows with low intensity. However, throughout the night streetlights remain switched

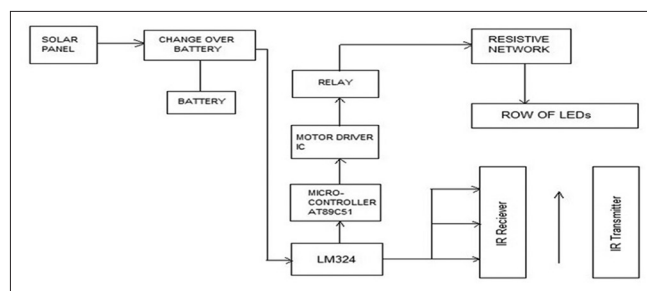

**Fig. 1** Block diagram of the automatic street light intensity controller

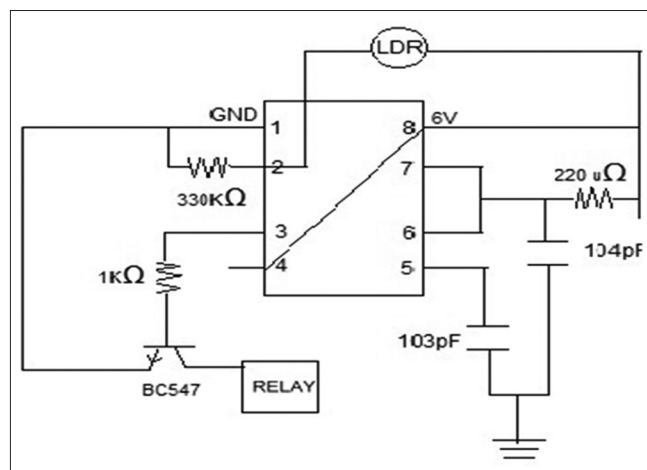

**Fig. 2:** LM555 Timer and change over circuit

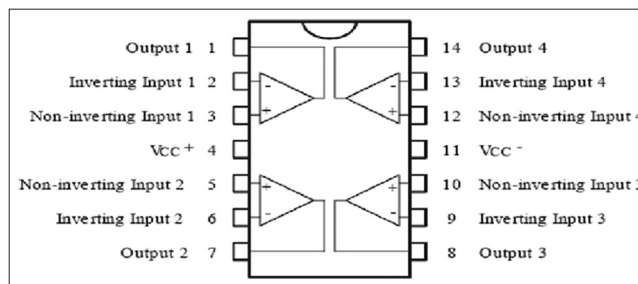

**Fig. 3:** LM324

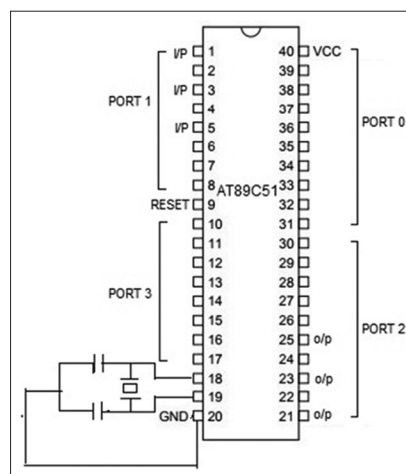

**Fig. 4:** AT89C51 microcontroller

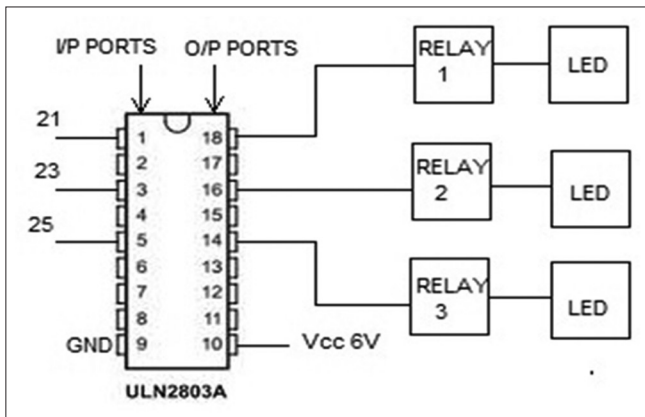

Fig. 5: IC ULN2803A

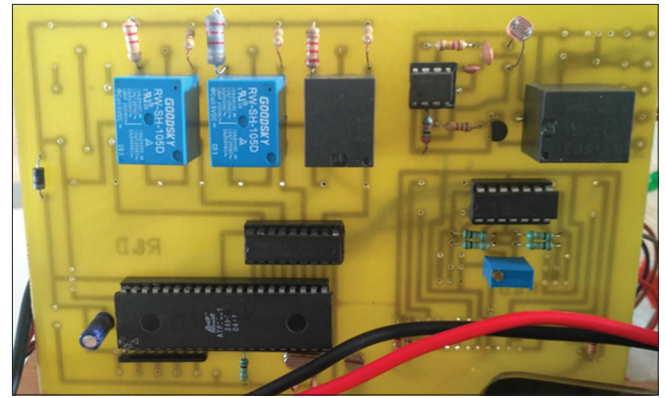

Fig. 6: Actual layout of PCB

on for security concerns on low intensity. When a vehicle passes by, a block of street lights glows, and as the vehicle moves forward, the next block of lights starts glowing where the previous block switches back to low intensity.

- It works in accordance with the varying sunlight. Whenever there is sufficient sunlight in surroundings, LDR exhibits high resistance and acts as an insulator, while in darkness this LDR behaves as low resistance path and allows the flows of electricity. This LDR operates with the help of IR sensors, which are activated under low illumination conditions and are controlled by the microcontroller. It drives the relays, which work as a switch, through the IC (ULN 2803) which gives the strength to the microcontroller to drives the relay.
- Solar panel in this system is an additional feature. It takes energy from the sun during the daytime and is stored in the battery, and this energy is being used during the dawn.

### CONCLUSION

Microcontroller based solar powered automatic street light intensity controller system was designed and executed in such a manner that the aim of conserving energy and dual power saver setup is justified. The problem of excessive loss of energy due to always ON position of street

lights even in the daytime and when there is no vehicle or pedestrian is overcome by the development of this system. With the implementation of this energy conservation system, the street lights will glow with low intensity in the dark hours and the intensity will increase when there is the motion of any vehicle or pedestrian. Whereas, lights will be kept OFF when there is sufficient amount of natural light is available. The proposed work would help in reducing the overall consumption of street light energy and support to energy-saving aspects of the nations.

### REFERENCES

- Vamshi Krishna V, Ramesh Babu N, Pradeep Kumar S, Ronald R, Street Light Automatic Intensity Controller, Int Res J Eng Technol. 2017; 4:1955-57.
- Devi DA, Kumar A. Design and implementation of CPLD based solar power saving system for street lights and automatic traffic controller. Int J Sci Res Publ 2012;2:1-3.
- Mohelnikova J. Electric Energy Savings and Light Guides, Energy and Environment. 3<sup>rd</sup> IASME/WSEAS International Conference, Cambridge, UK, February; 2008. p. 470-4.
- Sindhu AM, George J, Roy S, Chandra J. Smart streetlight using IR sensors. IOSR J Mob Computing Appl 2016;3:39-44.
- da Silva DI, Acosta-Avalos D. Light dependent resistance as a Sensor in spectroscopy setups using pulsed light and compared with electret microphones. Sensors 2006;6:514-25.